

saip.it



WAW Type

Welded
Diaphragm
Accumulators

Welded Diaphragm Accumulators WA Type



Principle Of Operation

One of the primary functions of hydraulic accumulators is to store a certain quantity of pressurized liquid from a hydraulic system and then release all or part of it back into the system when required. As pressurized vessels, they must be sized to withstand the maximum operational (over) pressure, while considering the acceptance standards applicable in the installation country. In the majority of hydraulic systems, accumulators with a separation element between the liquid side and the gas side are employed. Maintenance-free diaphragm accumulators, such as the WA type, consist of two high-strength steel caps that are electron-beam welded together. The U-shaped diaphragm separates the gas side from the liquid side. A dedicated bottom plate seals the opening on the liquid side when the accumulator is precharged to prevent diaphragm extrusion. The gas valve is available in the classic M28x1.5 version with a locking hexagon socket screw and a metal-rubber sealing washer (for precharging, the DP100 precharging and control equipment must be used). The liquid connection is available in standard threaded connections as specified in the table, in both female and double-threaded versions for quick, secure, and cost-effective anchoring through the external threading and locking nut (optional, see Accessories section), as well as an appropriate female connection. Compared to other types of accumulators, these diaphragm accumulators offer high energy efficiency due to their higher energy density (energy content per unit mass). This characteristic is attributed to the nearly spherical shape of the accumulator body. WA Type Diaphragm Accumulators can be installed in any position. Maintenance-free WA type diaphragm accumulators cannot be repaired.

Product Description

Non-repairable diaphragm accumulator with carbon steel caps, electron-beam welded, and painted, designed for use in mobile machinery and stationary systems.

Applications

- Energy storage in intermittent operation systems for pump power reduction.
- Energy reserve for emergency situations, such as pump unit failure or power outage.
- Compensation for losses due to leakage.
- Pressure compensation (balancing).
- Vibration damping in cases of periodic oscillations.
- Volume compensation in the presence of pressure and temperature variations.
- Hydraulic suspension spring for vehicles.
- Shock absorption in the event of mechanical impact.

Features

- A** Upper Cap
- B** Ring
- C** Diaphragm
- D** Bottom Plate
- E** MAG Welding
- F** Fluid connection
- G** Lower Cap
- H** Electron beam welding

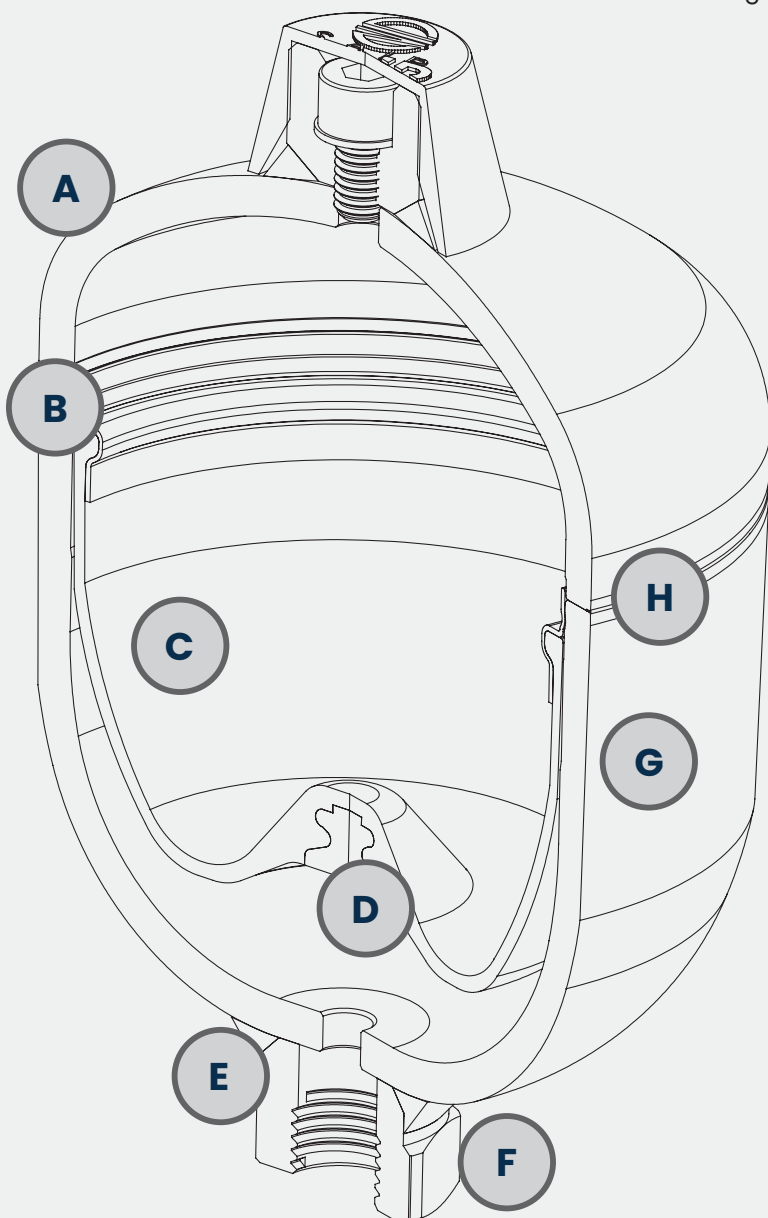

General Features

Nominal Volume
from 0,05 to 3,5 liters

Maximum pressure
MAX 350 barg

Compliant with
**PED 2014/68/EU EN
14359:2017
EN13445-3:2021**

Technical specifications

Non-repairable
electron beam welded
construction

High-strength alloy
steel body

Standard painting

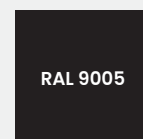

Two-component
anti-corrosion primer with
water-based epoxy resins,
alternatively
treatment of
Zinc-nickel plating

Gas side connection: M28x1.5

Fluid side connection
(see table)

*separator element
material : NBR, ECO
(see table for technical details)*

Description

Electron Beam Welded Diaphragm Accumulator WA Type - M28x1.5 - Vol. 0.75 L - NBR - Carb. Acc. - Fem. 1/2" GAS - Mod. 210 bar

EXAMPLE CODE*															
WA	.	2	.	0,75	.	1	.	O	.	G4	.	A	.	210	
1. ACCUMULATOR TYPE		2. GAS CONNECTION (NITROGEN)		3. NOMINAL VOLUME		4. SEPARATOR ELEMENT MATERIAL		5. BODY MATERIAL		6. FLUID CONNECTION		7. CERTIFICATION		8. DESIGN PRESSURE	
WA		CONNECTION M28X1,5		0,05		1 NITRILE (NBR)		O COATED CARBON STEEL		G4 F. 1/2" BSP-P		A PED 2014/68/EU EN 14359:2017 EN13445-3:2021		250	
				0,16		8 EPICHLOROHYDRIN (ECO)		OZN CARBON STEEL WITH ZINC-NICKEL TREATMENT**		A2 M. 1/4" BSP-P				250	
				0,35						G4 F. 1/2" BSP-P		100		250	
				0,5						M8 F. M18X1.5				210	
				0,75						G4 F. 1/2" BSP-P		100		210	
				1						M8 F. M18X1.5				280	
				1,4						G4 F. 1/2" BSP-P		210		280	
				2						E1 M. M33X1.5 + F. 1/2" BSP-P		140		250	
				3						M8 F. M18X1.5				350	
				3,5						G4 F. 1/2" BSP-P		140		250	
										E1 M. M33X1.5 + F. 1/2" BSP-P				350	
										G4 F. 1/2" BSP-P				250	
										Y9 F. 3/4" BSP-P				250	
										G4 F. 1/2" BSP-P				250	
										E1 M. M33X1.5 + F. 1/2" BSP-P				250	
										Y9 F. 3/4" BSP-P				250	
										Y9 F. 3/4" BSP-P				250	

* For different codes or specifications, please contact SAIP • ** 800 h salt spray resistance according to ISO 9227

Technical Data

Type	Nominal volume	Effective volume	Design pressure*	MAX ΔP ** dynamic $P_2 - P_1$	MAX Compression ratio $P_0 : P_2$	MAX*** Flow rate	MAX**** Precharge	PED Category (for group 2 fluids)	Weight
	[L]	[L]	[barg]	[barg]		[L/min]	[barg]		[kg]
WA 0,05	0,05	0,08	250	120	8:1	10	130	Art.4 Par.3	0,5
WA 0,16	0,16	0,17	250	120	8:1	10	130	Art.4 Par.3	0,9
WA 0,35	0,35	0,40	100	100	8:1	40	70	Art.4 Par.3	1,0
		0,44	250	140	8:1	40	130	Art.4 Par.3	1,7
WA 0,5	0,5	0,64	210	140	8:1	40	130	Art.4 Par.3	2,2
WA 0,75	0,75	0,80	100	120	6:1	90	70	Art.4 Par.3	2,0
		0,88	210	150	6:1	90	130	Art.4 Par.3	2,8
		0,76	280	150	6:1	90	130	Art.4 Par.3	3,1
		0,79	350	150	4:1	90	180	Art.4 Par.3	5,2
WA 1	1	1,14	210	140	6:1	90	130	Cat: II	3,5
		1,03	280	140	6:1	90	130	Cat: II	3,7
WA 1,4	1,4	1,52	140	80	6:1	90	100	Cat: II	4,0
		1,60	250	140	6:1	90	130	Cat: II	5,5
		1,40	350	140	4:1	90	180	Cat: II	8,5
WA 2	2	2,09	140	60	4:1	130	100	Cat: II	4,8
		2,11	250	140	4:1	130	130	Cat: II	6,5
		1,97	350	140	4:1	130	130	Cat: II	9,7
WA 3	3	3,30	250	140	4:1	130	130	Cat: II	10,0
WA 3,5	3,50	3,80	250	140	4:1	130	130	Cat: II	11,5

* Design Pressure calculated in accordance with EN14359:2017 (for pressure values in accordance with other standards, please contact SAIP).

** Maximum Allowable Differential Pressure (difference between maximum operating pressure P2 and minimum operating pressure P1) for an infinite cycle life (greater than 2,000,000 cycles).

*** Flow rate measured using mineral oil with a viscosity of 36 cSt at 50°C and $\Delta P = 5$ bar.

**** For value higher than this, please contact SAIP.

Models up to 280 bar

Technical drawing / Fluid connection G - M - Y

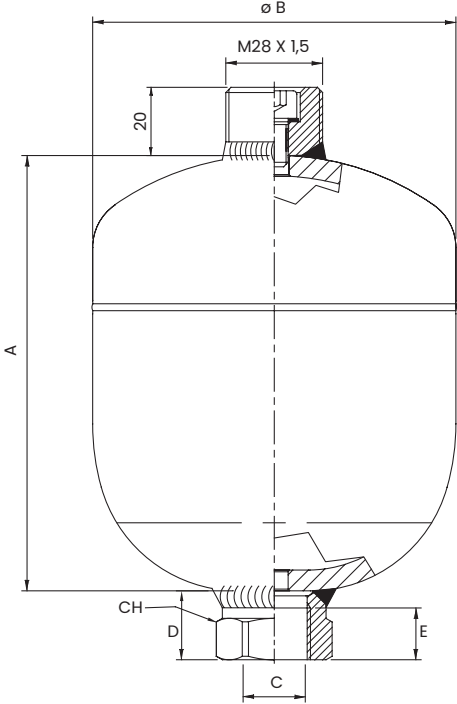

Technical drawing / Fluid connection E - A

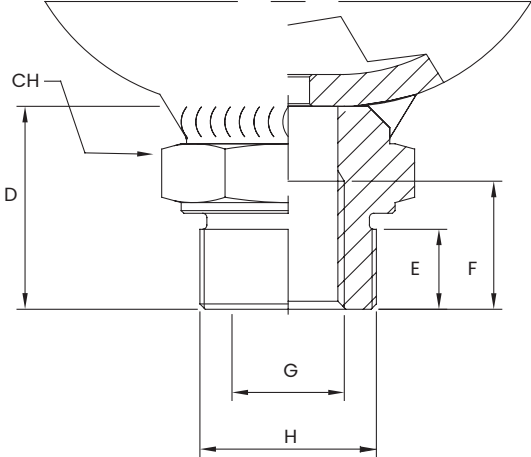

Models up to 350 bar

Technical drawing / Fluid connection G

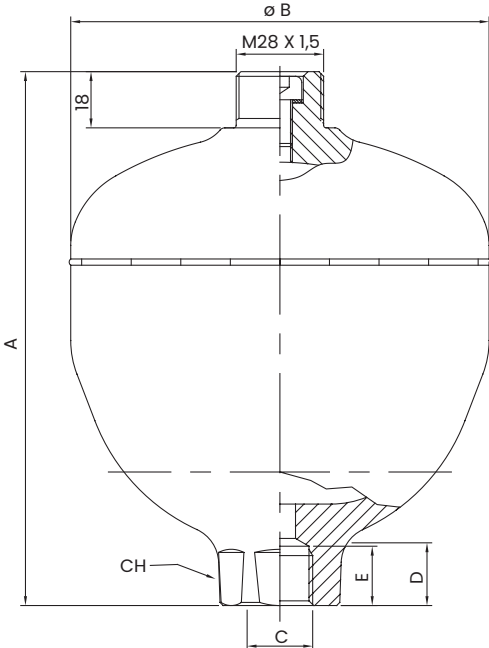

Technical drawing / Fluid connection E

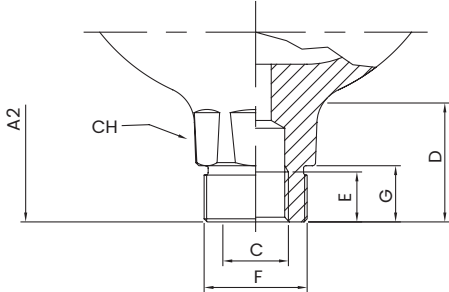

Models up to 280 bar

Dimensions

Type	Design pressure [barg]	Gas connection (Nitrogen)	A [mm]	B [mm]	Fluid connection G/M/Y				fluid connection E / A					
					C	E [mm]	D [mm]	CH [mm]	G	H	E [mm]	F [mm]	D [mm]	CH [mm]
WA 0,05	250	M28x1,5	65	55	F. 1/2" BSP-P	15	20	30	-	-	-	-	-	-
	250	M28x1,5	65	55	-	-	-	-	-	M 1/4" BSP-P	9	17	25	19
WA 0,16	250	M28x1,5	81,7	69	F. 1/2" BSP-P	15	20	30						
					F. M18x1,5	15	20	30						
WA 0,35	100	M28x1,5	99	91,5	F. 1/2" BSP-P	15	15	30						
					F. M18x1,5	15	20	30						
	250	M28x1,5	112	97	F. 1/2" BSP-P	15	20	30						
					F. M18x1,5	15	20	30						
WA 0,5	210	M28x1,5	126	105	F. 1/2" BSP-P	15	20	30						
					F. M18x1,5	15	20	30						
WA 0,75	100	M28x1,5	134	109	F. 1/2" BSP-P	15	20	30	F. 1/2" BSP-P	M.M33x1,5	15	24	38	41
					F. M18x1,5	15	20	30	F. 1/2" BSP-P	M.M33x1,5	15	24	38	41
	280	M28x1,5	132	117	F. 1/2" BSP-P	15	20	30	F. 1/2" BSP-P	M.M33x1,5	15	24	38	41
					F. M18x1,5	15	20	30	F. 1/2" BSP-P	M.M33x1,5	15	24	38	41
WA 1	210	M28x1,5	168	117	F. 1/2" BSP-P	15	20	30	F. 1/2" BSP-P	M.M33x1,5	15	24	38	41
					F. M18x1,5	15	20	30	F. 1/2" BSP-P	M.M33x1,5	15	24	38	41
WA 1,4	140	M28x1,5	153,2	143	F. 1/2" BSP-P	15	20	30	F. 1/2" BSP-P	M.M33x1,5	15	24	38	41
					F. M18x1,5	15	20	30	F. 1/2" BSP-P	M.M33x1,5	15	24	38	41
	250	M28x1,5	154	153	F. 1/2" BSP-P	15	20	30	F. 1/2" BSP-P	M.M33x1,5	15	24	38	41
					F. M18x1,5	15	20	30	F. 1/2" BSP-P	M.M33x1,5	15	24	38	41
WA 2	140	M28x1,5	196	143	F. 3/4" BSP-P	18	22	41						
					F. 1/2" BSP-P	15	20	30						
	250	M28x1,5	193	153	F. 3/4" BSP-P	18	22	41						
					F. 1/2" BSP-P	15	20	30						
WA 3	250	M28x1,5	242	174	F. 3/4" BSP-P	18	22	41						
WA 3,5	250	M28x1,5	276	174	F. 3/4" BSP-P	18	22	41						

Models up to 350 bar

Dimensions

Model	Pressione di Design [barg]	Gas connection (Nitrogen)	A [mm]	A2 [mm]	ØB [mm]	Fluid connection G				Fluid connection E					
						C	E [mm]	D [mm]	CH [mm]	C	F	E [mm]	G [mm]	D [mm]	CH [mm]
WA0,75	350	M28x1,5	171	189	134	F. 1/2" BSP-P	16	20	41	F. 1/2" BSP-P	M.M33x1,5	16	18	37	41
WA 1,4	350	M28x1,5	201	219	162	F. 1/2" BSP-P	16	20	41	F. 1/2" BSP-P	M.M33x1,5	16	18	37	41
WA 2	350	M28x1,5	246	264	162	F. 1/2" BSP-P	16	20	41	F. 1/2" BSP-P	M.M33x1,5	16	18	37	41

Status conditions

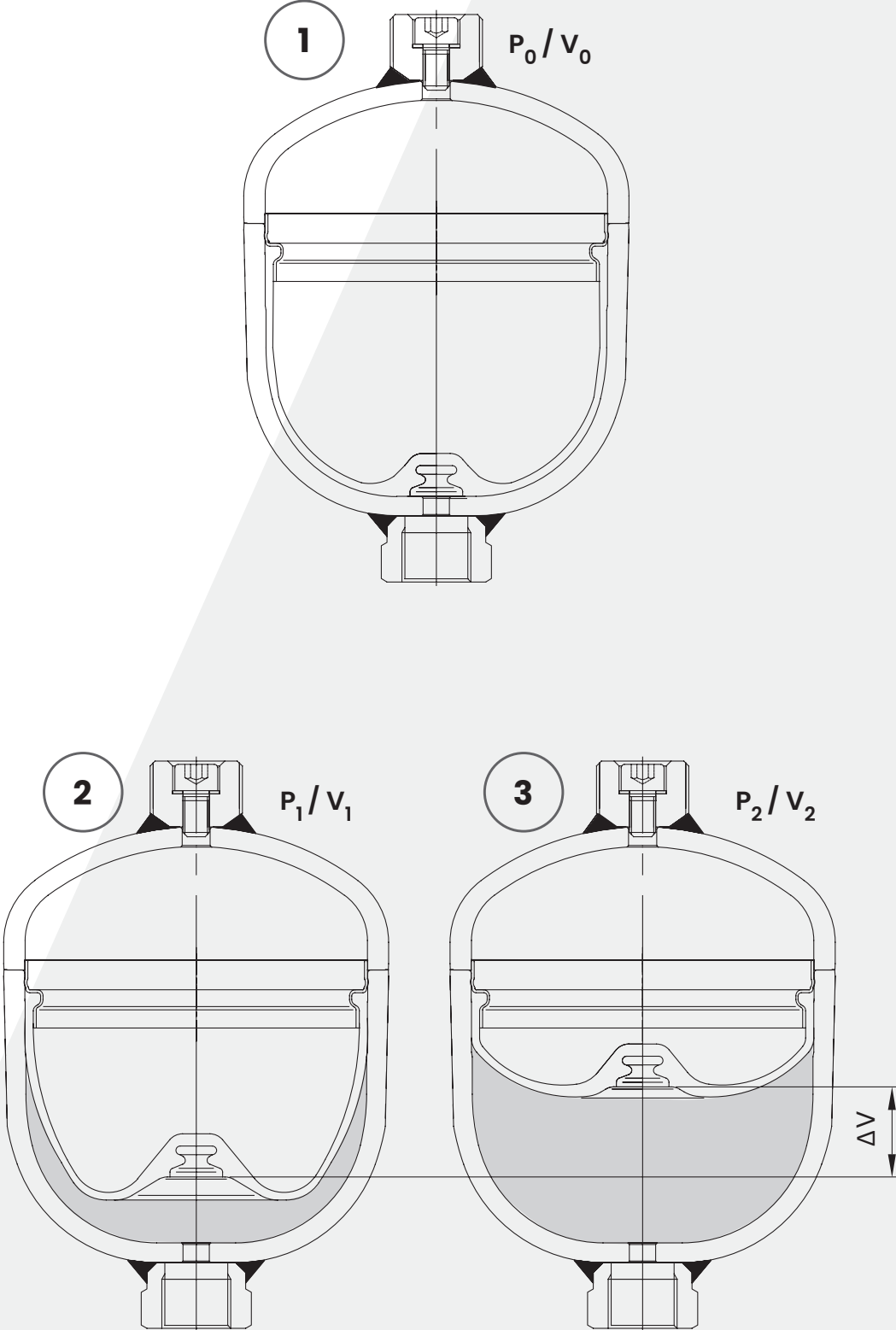

Sizing

The sizing of an accumulator requires the consideration of various factors:

- Minimum (P1) and maximum (P2) working pressures.
- Minimum (T1) and maximum (T2) working temperatures.
- Precharge pressure (P0).
- Required volumes.

For the correct sizing, you can find the formulas in the document under the section

GENERAL INFORMATION -> SIZING

Usage information

Please refer to the following SAIP documents:

- WA USER AND MAINTENANCE MANUAL
- USER MANUAL FOR THE STORAGE AND PRESERVATION OF HYDRAULIC ACCUMULATORS/PULSATION DAMPENERS



Certifications

All hydraulic accumulators are pressure vessels and are subject to national regulations and the directives applicable in the country of installation. WA type accumulators are constructed in accordance with the European Directive PED 2014/68/EU.

In the Technical Data table, the category of use is specified for non-hazardous fluids (Group 2).

For use with hazardous fluids (Group 1), please contact SAIP. For other countries, applications, or regulations, please get in touch with SAIP for further information and guidance.

Safety Equipment

Warning:

Hydropneumatic accumulators must be protected against operation beyond permissible limits in accordance with Directive 2014/68/EU on pressure equipment.

Membrane Compatibility / Temperature / Fluid *			
1	Nitrile Butadiene Rubber (NBR)	-15 / +80°C	<p>Suitable for:</p> <p>Mineral greases and oils.</p> <p>Aliphatic hydrocarbons (propane, butane, gasoline, mineral oils, diesel fuel, heating oil, kerosene).</p> <p>HFA - HFB - HFC fluids.</p> <p>Many diluted acids.</p> <p>Saline solutions.</p> <p>Water.</p> <p>Water-glycol solutions.</p>
8	Epichlorohydrin Rubber (ECO)	-30 / +120°C	<p>Low gas permeability, good resistance to ozone, aging, and atmospheric agents.</p> <p>Suitable for:</p> <p>Mineral greases and oils.</p> <p>Aliphatic hydrocarbons (propane, butane, gasoline).</p> <p>Silicone oils and greases.</p> <p>Water at room temperature.</p>

* For use with other fluids and/or temperatures, please contact SAIP.

Surface treatments	
O	carbon steel painted RAL 9005 two-component anticorrosive primer with water-based epoxy resins
OZN	zinc-nickel plated carbon steel, 800 h resistance in salt spray before the appearance of red corrosion according to ISO 9227

fluid connection	
G4	F. 1/2" BSP-P (without grooving)
M8	F. M18x1,5 (without grooving)
Y9	F. 3/4" BSP-P (with grooving ø 34)
E1	M. M33x1,5 + F. 1/2" BSP-P (without grooving)
A2	M.1/4" BSP-P

Fastening Nut

Used for securely and easily fastening accumulators through the external threading on the fluid side fitting M33x1.5 or M45x1.5 and/or through the gas side connection M28x1.5 threading. The nuts are made of carbon steel with a white zinc plating treatment, providing excellent corrosion resistance.

Type	D	SW [mm]	H [mm]
DADORM2-OZ28	M28 x 1,5	41	7
DADORE1-OZ33	M33 x 1,5	50	7

Fastening Collars

The SAIP fastening collars type CFOZ_LF_ can be used to securely fasten the various types of WA accumulators and guarantee an independent, non-rigid mounting on the systems. The NBR rubber insert reduces the transmission of vibrations, compensates manufacturing tolerances and relieves external stresses on the connection. This type of collar has a two-piece construction for easier installation, greater modularity and stability according to requirements and available space.

Description	Material	Salt spray resistance according to ISO 9227 [h]
STD COLLAR	galvanised carbon steel	72
INOX COLLAR	AISI 316 stainless steel	400

Technical Drawing / NUT

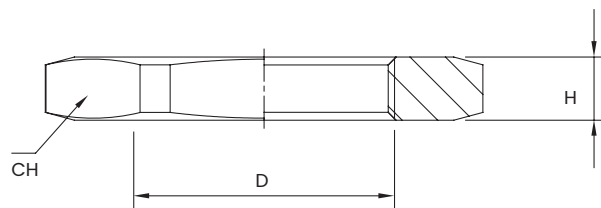

Technical Drawing / Fastening collar light series

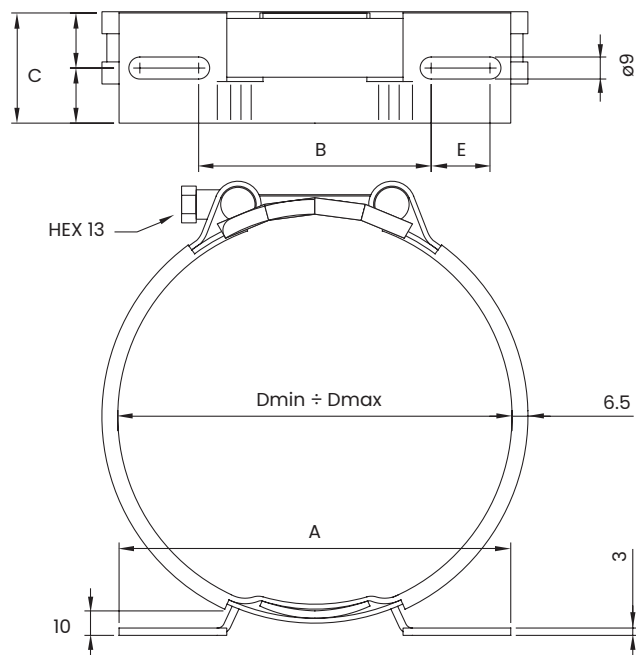

Type		Description							Weight	WA usage
MATERIAL		Dmin	Dmax	A	B	C	E			
AISI 316L	CARBON STEEL	[mm]		[mm ±1]		[mm ±0,5]		[Kg]	WA Model (barg)	
CFXZ72LF120	CFOZ72LF120	67	72	124	81	45	13	0,3	WA 0,16	
CFXZ96LF120	CFOZ96LF120	91	96	124	81	45	13	0,3	WA 0,35 (100)	
CFXZ96LF160	CFOZ96LF160			144	93	45	17	0,5		
CFX102LF160	CFOZ102LF160	97	105	144	93	45	17	0,5	WA0,35 (250) - WA 0,5 (210)	
CFX111LF160	CFOZ111LF160	106	114	144	93	45	17	0,5	WA 0,75 (100)	
CFX120LF160	CFOZ120LF160	115	123	144	93	45	17	0,5	WA 0,75 (210, 280) - WA1 (210-280)	
CFX137LF160	CFOZ137LF160	133	141	144	93	45	17	0,5	WA 0,75 (350)	
CFX146LF160	CFOZ146LF160	141	154	144	93	45	17	0,5	WA 1,4 (140 -250) -2 (140-250)	
CFX146LF210	CFOZ146LF210			214	145	50	24	0,5		
CFX159LF160	CFOZ159LF160	155	167	144	93	45	17	0,5	1,4 (350) - 2 (350)	
CFX159LF210	CFOZ159LF210			214	145	50	24	0,5		
CFX172LF160	CFOZ172LF160	168	181	144	93	45	17	0,5	WA 3-3,5 (250)	
CFX172LF210	CFOZ172LF210			214	145	50	24	0,5		



WA - rev. March 2025

saip.it

SAIP S.r.l.
Hydropneumatic
Accumulator Company

Via Lambro 23/25/27
20073 Opera (MI) Italy
P.Iva 10218550159

[DONWLOAD
DATA SHEET](#)

